

COBRA C.L.A.W. (COVERT LIGHT AERIAL WEAPON)

- 1) ELECTRONICS ACCESS PANEL
- 2) PRIMARY CONTROL ACCESS PANEL
- 3) EXTENDABLE WINGTIPS
- 4) UNGUIDED 10-LB HE-8 VENOM MISSILES
- 5) AUXILIARY COOLING SLOTS
- 6) VERTICAL STABILIZER SURFACES
- 7) MACHINE GUN ACCESS SHROUD
- 8) SECONDARY AIR INTAKES
- 9) GAS-PRESSURIZED MAIN SHOCK ABSORBERS
- 10) ENGINE REPAIR ACCESS PANEL
- 11) 2X DES/MINI-55 TURBOJET ENGINES
- 12) LEG SHIELDS
- 13) 2000 RPM 7.6MM MACHINE GUN
- 14) FINGERTIP ROLLER-TYPE CONTROLS
- 15) DES/28-B 750-LB FLASHFIRE BOMB

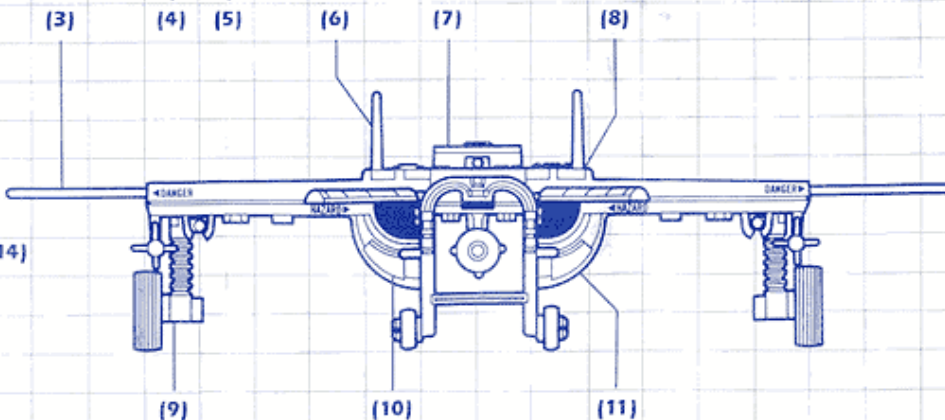
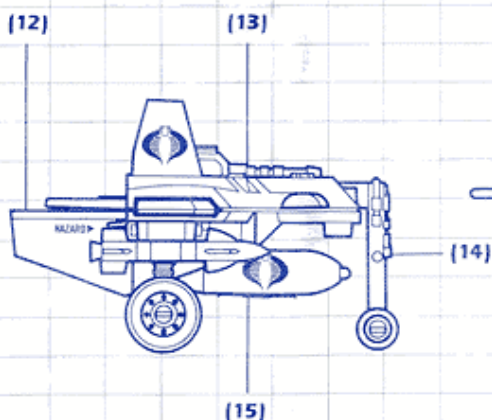
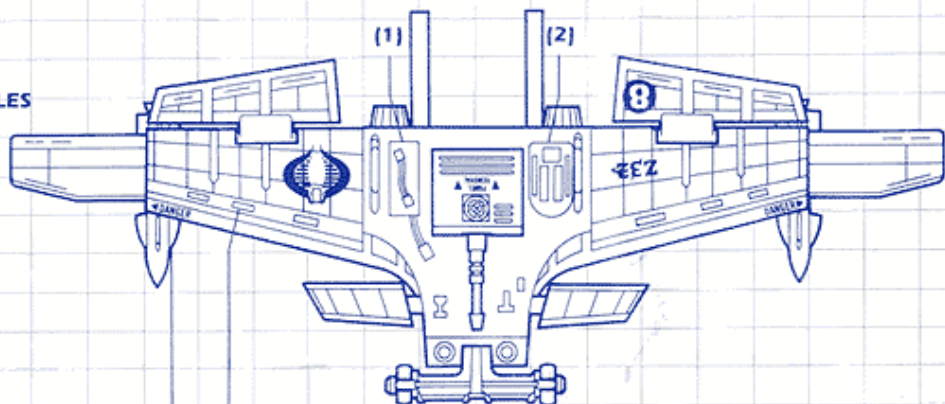

COBRA C.L.A.W. INSTRUCTIONS

First gently remove all pieces from their runners. Supervision necessary for assembly.

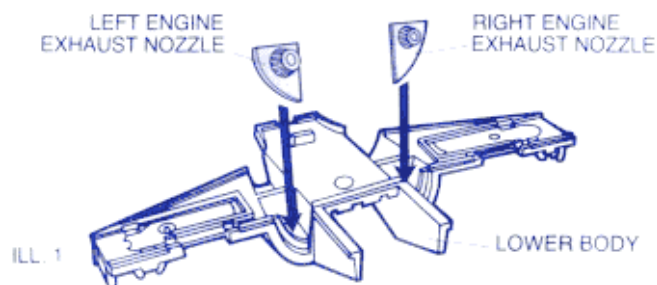

1 Insert left and right engine exhaust nozzles into slots in lower body. Press into place. (ILL. 1)

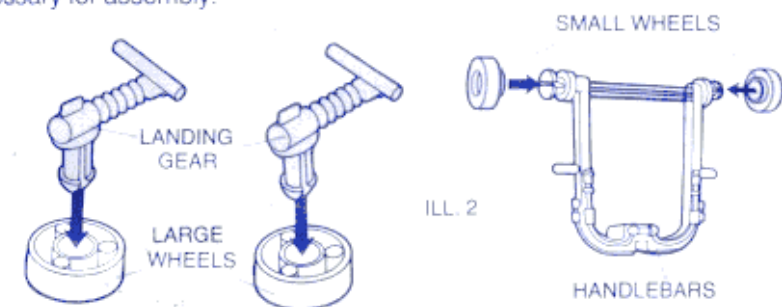

2 Snap landing gear into large wheels. Snap small wheels onto ends of handlebars. (ILL. 2)

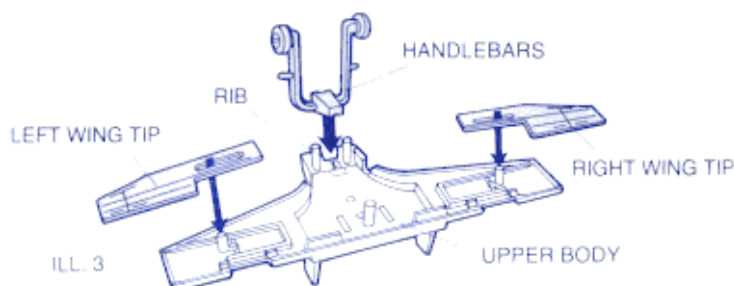

3 Place tab on handlebars over rib on upper body. Place left and right wing tips over the posts on upper body and within the wing tip guides. (ILL. 3)

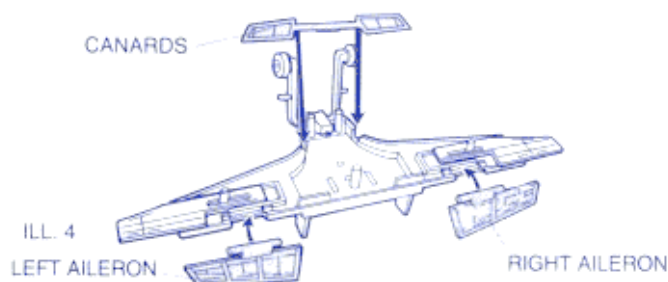

4 Place left and right ailerons onto upper body. Place canards (curved side face down) onto upper body. (ILL. 4)

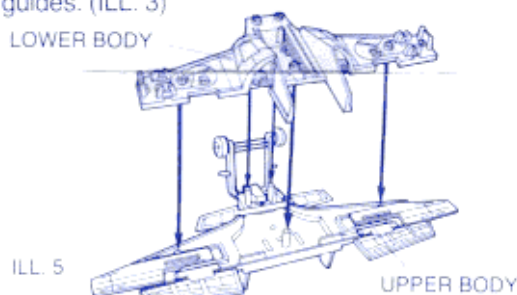

5 Press lower body over upper body. (ILL. 5)

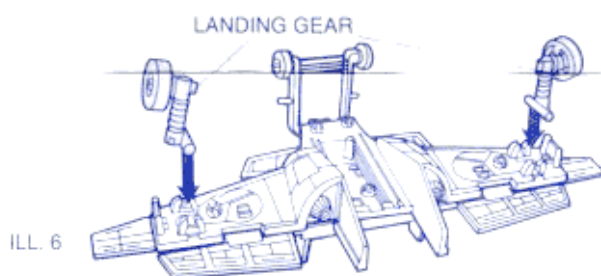

6 Push posts on landing gear into slots shown with wheels facing outward. Wheels snap under the wings for landing. (ILL. 6)



7 Place Venom missiles over posts at the ends of the wings. Press bomb halves together. Place Flashfire bomb over the post in the middle of the C.L.A.W. (ILL. 7)

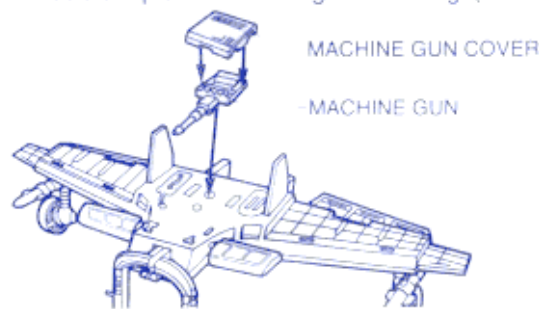

8 Press machine gun into holes on top of the C.L.A.W. Press cover over the machine gun. (ILL. 8)
You can remove the Flashfire bomb and place a COBRA figure on the post instead. (Figure sold separately.)

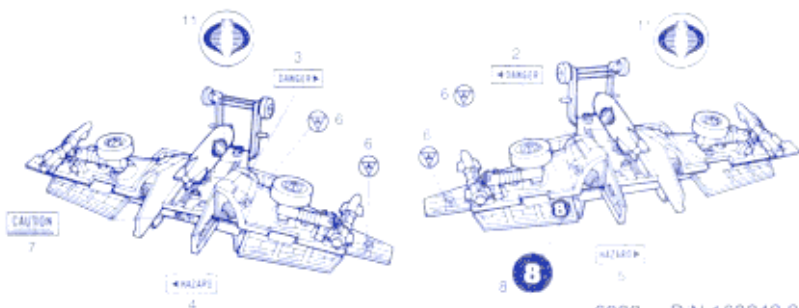
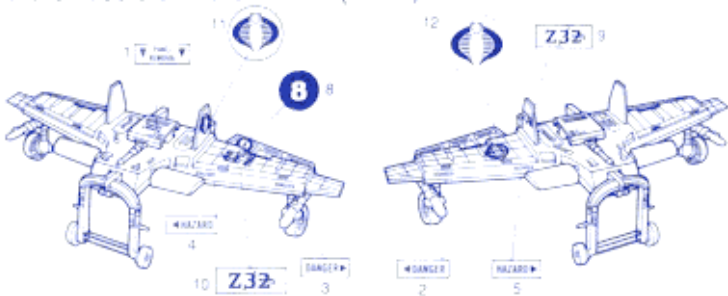

Peel labels off label sheets and apply as shown.
© 1983 Hasbro Industries, Inc., Pawtucket, RI 02861 USA.